



Performance Specification

Model	Marking	V _{max} (V dc)	I _{max} (A)	I _{hold} @25°C (A)	I _{trip} @25°C (A)	P _d Typ. (W)	Maximum Time To Trip		Resistance	
							Current (A)	Time (Sec)	R _{i min} (Ω)	R _{1max} (Ω)
SMD0805R020SF	2	9.0	100	0.20	0.50	0.5	8.0	0.02	0.650	3.500
SMD0805R035SF	3	6.0	100	0.35	0.75	0.5	8.0	0.10	0.250	1.200
SMD0805R050SF	5	6.0	100	0.50	1.00	0.5	8.0	0.10	0.150	0.850
SMD0805R075SF	7	6.0	40	0.75	1.50	0.6	8.0	0.20	0.090	0.385
SMD0805R100SF	0	6.0	100	1.00	1.95	0.6	8.0	0.30	0.060	0.230
SMD0805R110SF	0	6.0	100	1.10	2.20	0.6	8.0	0.30	0.060	0.210
SMD0805R125SF	12	6.0	100	1.25	2.50	1.5	8.0	0.60	0.030	0.140

- I_{hold} = Hold Current. Maximum current device will not trip in 25°C still air.
- I_{trip} = Trip Current. Minimum current at which the device will always trip in 25°C still air.
- V_{max} = Maximum operating voltage device can withstand without damage at rated current (I_{max}).
- I_{max} = Maximum fault current device can withstand without damage at rated voltage (V_{max}).
- P_d = Power dissipation when device is in the tripped state in 25°C still air environment at rated voltage.
- R_{i min/max} = Minimum/Maximum device resistance prior to tripping at 25°C.
- R_{1max} = Maximum device resistance is measured one hour post reflow.
- CAUTION : Operation beyond the specified ratings may result in damage and possible arcing and flame.

Environmental Specifications

Test	Conditions	Resistance change
Passive aging	+85°C, 1000 hrs.	±5% typical
Humidity aging	+85°C, 85% R.H. , 168 hours	±5% typical
Thermal shock	+85°C to -40°C, 20 times	±33% typical
Resistance to solvent	MIL-STD-202, Method 215	No change
Vibration	MIL-STD-202, Method 201	No change
Ambient operating conditions : - 40 °C to +85 °C		
Maximum surface temperature of the device in the tripped state is 125 °C		



Thermal Derating Chart

Recommended Hold Current(A) at Ambient Temperature(°C)

Model	Ambient Operation Temperature								
	-40°C	-20°C	0°C	25°C	40°C	50°C	60°C	70°C	85°C
SMD0805R010SF	0.14	0.12	0.11	0.10	0.08	0.07	0.06	0.05	0.03
SMD0805R020SF	0.28	0.25	0.23	0.20	0.17	0.14	0.12	0.10	0.07
SMD0805R035SF	0.47	0.44	0.39	0.35	0.30	0.27	0.24	0.20	0.14
SMD0805R050SF	0.68	0.62	0.55	0.50	0.40	0.37	0.33	0.29	0.23
SMD0805R075SF	1.00	0.90	0.79	0.75	0.63	0.57	0.53	0.41	0.34
SMD0805R100SF	1.35	1.25	1.15	1.00	0.82	0.74	0.65	0.55	0.42
SMD0805R110SF	1.45	1.35	1.20	1.10	0.92	0.84	0.75	0.65	0.52
SMD0805R125SF	1.65	1.53	1.36	1.25	1.05	0.95	0.85	0.74	0.59

Thermal Derating Curve

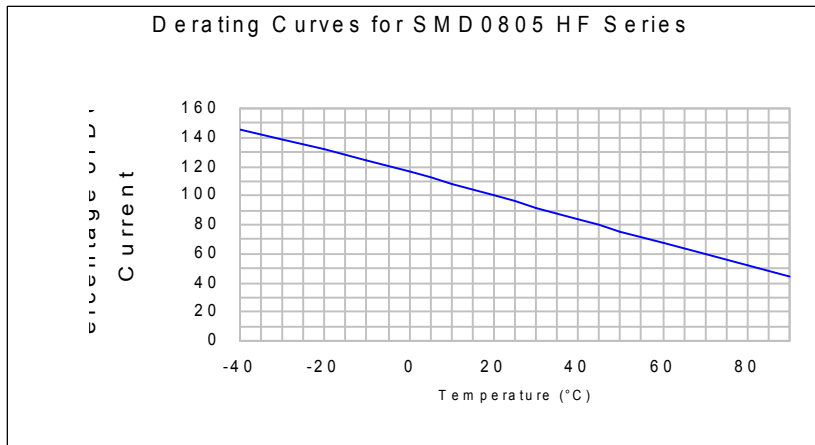

Average Time-Current Curve

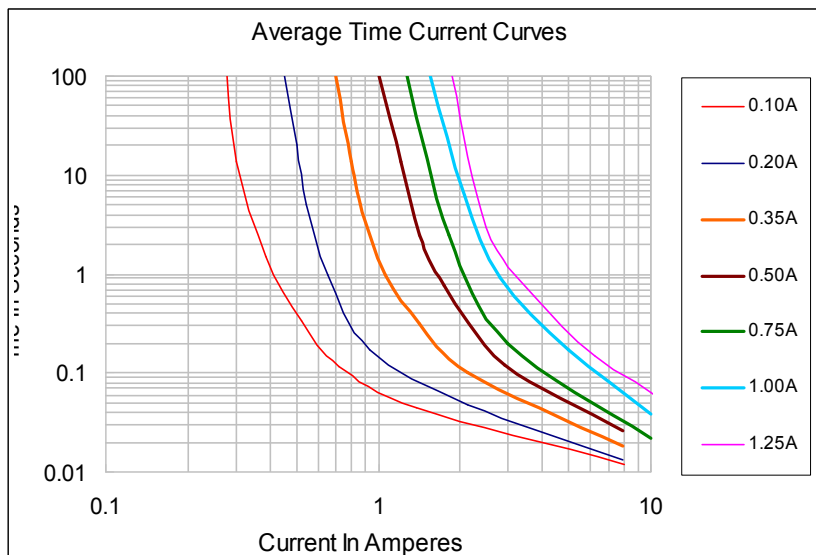



Soldering Parameters

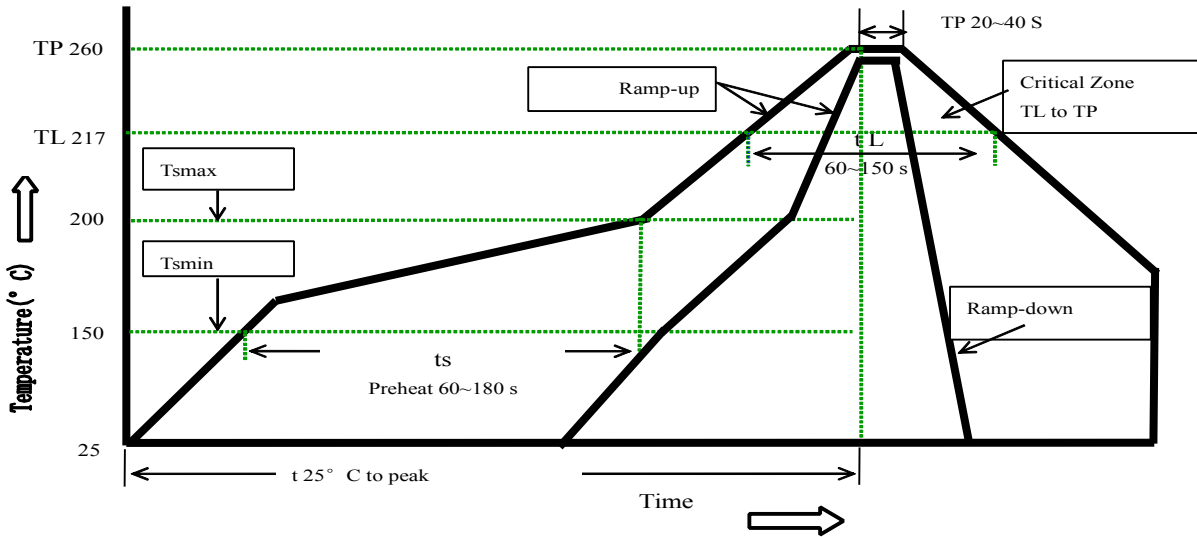

Profile Feature	Pb-Free Assembly
Average Ramp-Up Rate(Ts max to T p)	3°C/second max.
Preheat	
-Temperature Min(Ts min)	150°C
-Temperature Max(Ts max)	200°C
-Time(Ts min to Ts max)	60~180 seconds
Time maintained above:	
-Temperature(TL)	217°C
-Time(tL)	60~150 seconds
Peak Temperature(Tp)	260°C
Ramp-Down Rate	6°C/second max.
Time 25°C to Peak Temperature	8 minutes max
Storage Condition	0°C~35°C, ≤70%RH

Recommended reflow methods: IR, vapor phase oven, hot air oven, N2 environment for lead-free

Recommended maximum paste thickness is 0.25mm

Devices can be cleaned using standard industry methods and solvents.

Note 1: All temperature refer to topside of the package, measured on the package body surface.

Note 2: If reflow temperatures exceed the recommended profile, devices may not meet the performance requirements.



Physical Dimensions(mm.)

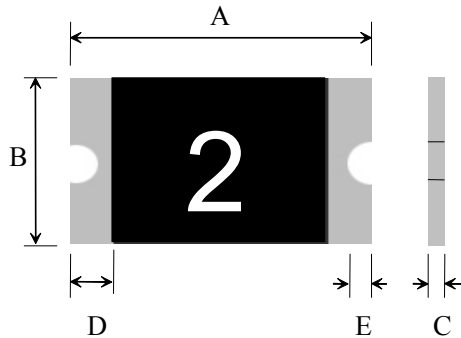

Model	A		B		C		D	E
	Min.	Max.	Min.	Max.	Min.	Max.	Min.	Min.
SMD0805R010SF	2.00	2.20	1.20	1.50	0.50	1.00	0.20	0.10
SMD0805R020SF	2.00	2.20	1.20	1.50	0.45	1.00	0.20	0.10
SMD0805R035SF	2.00	2.20	1.20	1.50	0.45	1.00	0.20	0.10
SMD0805R050SF	2.00	2.20	1.20	1.50	0.30	0.60	0.20	0.10
SMD0805R075SF	2.00	2.20	1.20	1.50	0.40	1.00	0.20	0.10
SMD0805R100SF	2.00	2.20	1.20	1.50	0.50	1.10	0.20	0.10
SMD0805R110SF	2.00	2.20	1.20	1.50	0.50	1.20	0.20	0.10
SMD0805R125SF	2.00	2.20	1.20	1.50	0.50	1.20	0.20	0.10

Termination Pad Characteristics

Terminal pad materials: Tin-plated Nickel-Copper

Terminal pad solder ability: Meets EIA specification RS186-9E and ANSI/J-STD-002 Category 3.

Recommended Pad Layout (mm.)

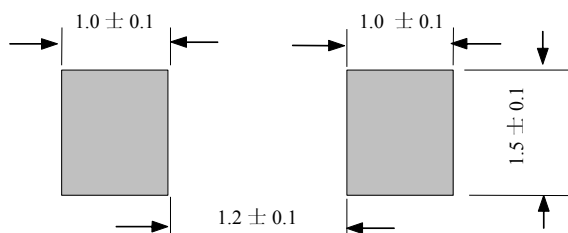



Tape And Reel Specifications (mm)

Governing Specifications	EIA 481-1
W	8.0 ± 0.3
P0	4.0 ± 0.10
P1	4.0 ± 0.10
P2	2.0 ± 0.05
A0	1.45 ± 0.10
B0	2.30 ± 0.10
B1max.	4.35
D0	1.55 + 0.1, -0
F	3.5 ± 0.05
E1	1.75 ± 0.10
E2min.	6.25
T	0.25
T1max.	0.1
K0	0.74 ± 0.1
Leader min.	390
Trailer min.	160
Reel Dimensions	
A max.	178
N min.	60
W1	9.0 ± 0.5
W2	12.0 ± 0.05

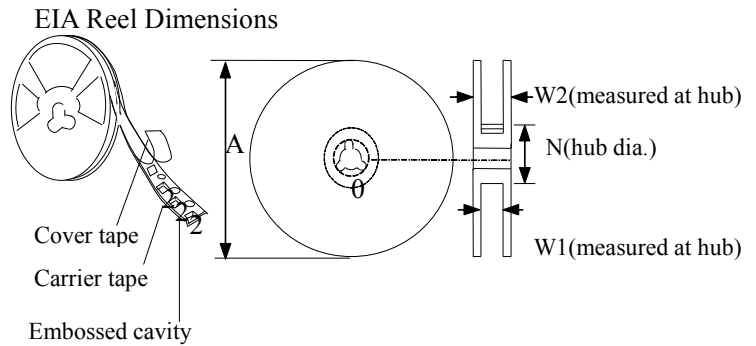
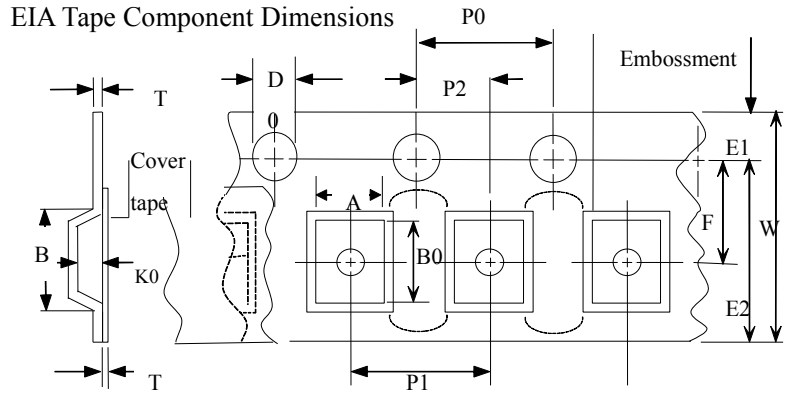

Storage And Handling

- Storage conditions: 40°C max, 70% R.H.
- Devices may not meet specified performance if storage conditions are exceeded.

Part Number System

SMD 0805 R □□□ S F □□ V

