



Varistor>53D201~162K Series

Applications



- Transistor, diode, IC, thyristor or triac semiconductor protection.
- Surge protection in consumer electronics.
- Surge protection in industrial electronics.
- Surge protection in electronic home appliances, gas and petroleum appliances.
- Relay and electromagnetic valve surge absorption.

Features

- Wide operating voltage (V1mA) range from 8V to 1800V.
- Fast responding to transient over-voltage.
- Large absorbing transient energy capability.
- Low clamping ratio and no following-on current.

General Information

The MOV-40DxxxK Series of 40 mm radial leaded varistor devices protects against overvoltage transients such as lightning, power contact and power induction. The metal oxide varistors offer a choice of varistor voltages from 200 V to 1600 V and Vrms voltages from 130 V to 1000 V.

The devices have a high current handling, high energy absorption capability and fast response times to protect against transient faults up to rated limits.

General Characteristics

No Radioactive Material

Storage Temperature: -55°C to +125°C

Operating Temperature: -55°C to +85°C

Body: Nickel Plated

Leads: Surface-mount, Axial Devices: Tin Plated

Devices with No Leads: Nickel Plated

Packaging Information

Part Number	Component package	Quantity	Packaging Option	Packaging Specification
53D	53.0	100	BOX	200PCS

Product Name

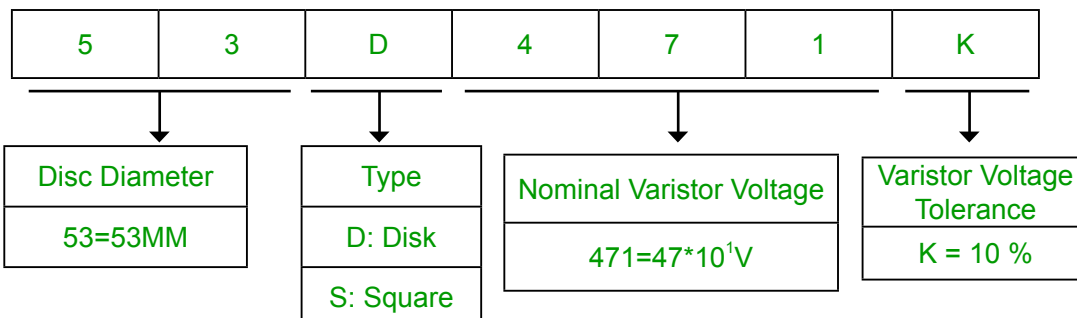



Varistor>53D201~162K Series

Electrical Characteristics (@ TA = 25 °C Unless Otherwise Noted)

Type Number	Maximum Allowable Voltage		Varistor Voltage	Maximum Clamping Voltage		Withstanding Surge Current	Maximum Energy (10/1000μs)	Typical Capacitance (Reference)
	V _{AC} (V)	V _{DC} (V)	V _{1mA} (V)	I _P (A)	V _C (V)	I(A)	(J)	@1KHz(pf)
53D201K	130	170	200(180~220)	500	340	70000	550	15000
53D221K	140	180	220(198~242)	500	360	70000	600	13750
53D241K	150	200	240(216~264)	500	395	70000	650	12500
53D271K	175	225	270(243~297)	500	455	70000	700	11000
53D301K	190	250	300(270~330)	500	500	70000	765	10000
53D331K	210	275	330(297~363)	500	550	70000	825	9000
53D361K	230	300	360(324~396)	500	595	70000	850	8500
53D391K	250	320	390(351~429)	500	650	70000	885	7500
53D431K	275	350	430(387~473)	500	710	70000	990	7000
53D471K	300	385	470(423~517)	500	775	70000	1080	6500
53D511K	320	415	510(459~561)	500	845	70000	1150	6000
53D561K	350	460	560(504~616)	500	925	70000	1200	5500
53D621K	385	505	620(558~682)	500	1025	70000	1300	5000
53D681K	420	560	680(612~748)	500	1120	70000	1350	4500
53D751K	460	615	750(675~825)	500	1240	70000	1400	4000
53D781K	485	640	780(702~858)	500	1290	70000	1450	3900
53D821K	510	670	820(738~902)	500	1355	70000	1600	3700
53D911K	550	745	910(819~1001)	500	1500	70000	1700	3300
53D951K	575	765	950(855~1045)	500	1570	70000	1800	3200
53D102K	625	825	1000(900~1100)	500	1650	70000	1890	3000
53D112K	680	895	1100(990~1210)	500	1815	70000	2050	2700
53D122K	750	990	1200(1080~1320)	500	1980	70000	2050	2500
53D142K	880	1140	1400(1260~1540)	500	2310	70000	2300	2150
53D162K	1000	1280	1600(1440~1760)	500	2640	70000	2500	1900

The tolerance of varistor voltage between 18V and 27V is more than 10%.



Varistor>53D201~162K Series

Current Energy and Power Dissipation Ratings

Should transients occur in rapid succession, the average power dissipation is the energy (watt-seconds) per pulse times the number of pulses per second. The power so developed must be within the specifications shown on the Device Ratings and Specifications Table for the specific

device. The operating values of a MOV need to be derated at high temperatures as shown above. Because varistors only dissipate a relatively small amount of average power they are not suitable for repetitive applications that involve substantial amounts of average power dissipation.

Figure 1A - Power Derating for Epoxy Coated

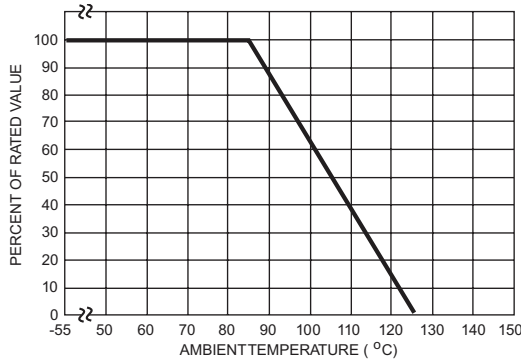
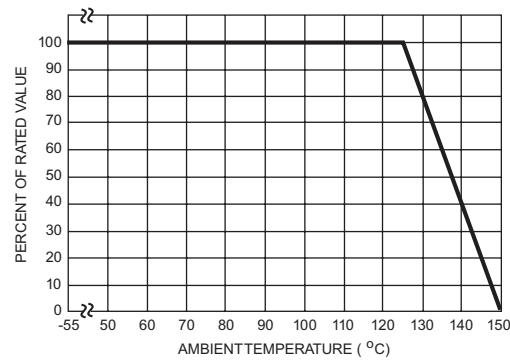

Figure 1B - Power Derating for Pholenic Coated



Peak Pulse Current Test Waveform

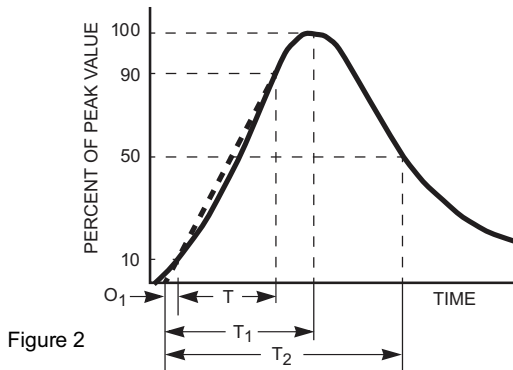

Figure 2

- O_1 = Virtual Origin of Wave
- T = Time from 10% to 90% of Peak
- T_1 = Rise Time = $1.25 \times T$
- T_2 = Decay Time

Example - For an 8/20 μ s Current Waveform:

- $8\mu\text{s} = T_1 = \text{Rise Time}$
- $20\mu\text{s} = T_2 = \text{Decay Time}$



Varistor>53D201~162K Series

Package Dimensions

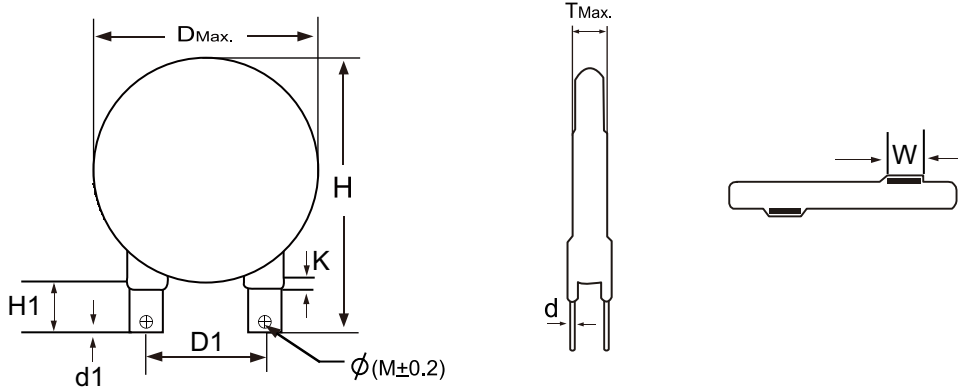

Unit:mm

TABLE 1

Symbol	Dimensions
H(max.)	78.2
H1(max.)	16.5
D(max.)	45
D1(+1.0)	25.4
T(max.)	TABLE 2
d(+0.1)	0.5
d1(+0.3)	3.4
K(max.)	3.18
W(+0.5)	9.7
Ø (M+0.2)	4.15

TABLE 2

Model	T(max.)	Model	T(max.)
201K	6.3	911K	10.5
221K	6.4	951K	10.7
241K	6.5	102K	11.3
271K	6.7	112K	11.9
301K	6.9	122K	12.4
331K	7.0	142K	13.4
361K	7.2	162K	14.4