



GDT > 3216 series

Features

- ✧ High insulation resistance.
- ✧ Low capacitance ($\leq 0.5\text{pF}$).
- ✧ Max Surge current capacity 500A 8/20 μs .
- ✧ Accord with ITU-TK.21 standard 4KV 10/700 μs
- ✧ Surface Mounted Gas Arrester
- ✧ Micro-Gap Design
- ✧ Size 3216(1206)
- ✧ Storage and operational temperature: $-40^{\circ}\text{C} \sim +85^{\circ}\text{C}$
- ✧ Meets MSL level 1, per J -STD-020



Application

- ✧ Repeaters, Modems.
- ✧ Telephone Interface, Line cards.
- ✧ Data communication equipment.
- ✧ Line test equipment.

Part Number Code

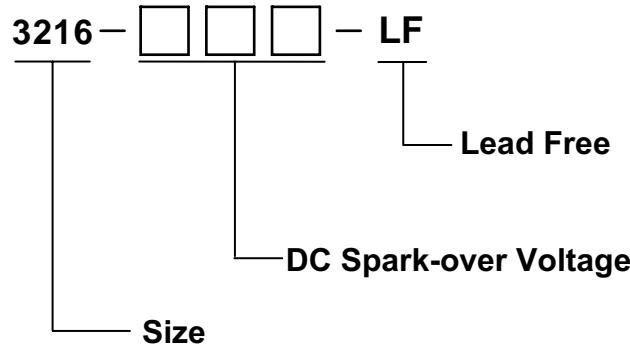

Dimensions

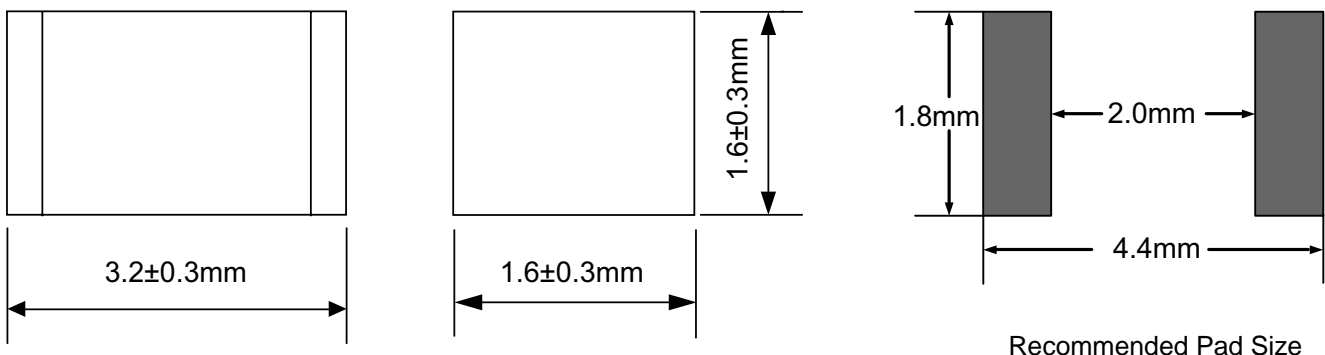



GDT > 3216 series

Electrical Characteristic

Part Number	DC Spark-over Voltage	Impulse Spark-over Voltage	Minimum Insulation Resistance		Maximum Capacitance	Nominal Impulse Discharge Current	Impulse Discharge Voltage
	100V/s	1000V/ μ s	Test Voltage	(M Ω)	(1MHz)	8/20 μ s	
	(V)	(V)	DC(V)		(pF)	(A)	
3216-150-LF	150 \pm 30%	<750	50	1000	0.5	500	10/700 μ s 4kV
3216-230-LF	230 \pm 30%	<950	100	1000	0.5	500	
3216-300-LF	300 \pm 30%	<950	100	1000	0.5	500	
3216-350-LF	350 \pm 30%	<950	100	1000	0.5	500	
3216-400-LF	400 \pm 30%	<1050	100	1000	0.5	500	
3216-420-LF	420 \pm 30%	<1050	100	1000	0.5	500	
3216-470-LF	470 \pm 30%	<1050	100	1000	0.5	500	

Electrical Rating

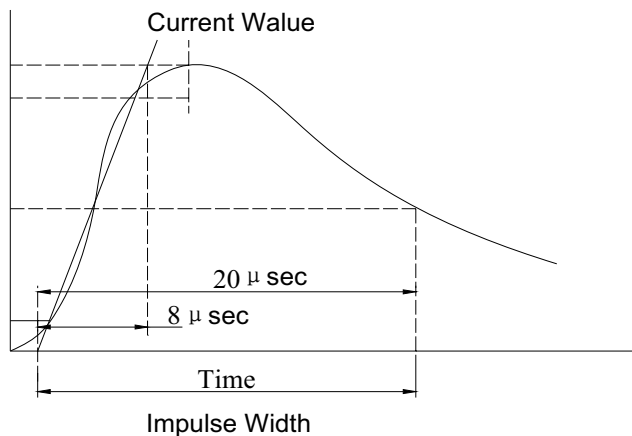
Items	Test Condition / Description	Requirement
DC Spark-over Voltage	The voltage is measured with a low rate of rise $dv / dt = 100V/s$	To meet the specified value
Impulse Discharge Current	<p>The maximum current applying a waveform of 8/20μs that can be applied across the terminals of the gas tube without causing the more than $\pm 30\%$ from its initial measured DC breakdown voltage.</p> <p>Dwell time between pulses is 3 minutes.</p>  <p>The graph shows a current pulse starting at time zero, rising to a peak labeled 'Current Value'. The time from the start to the peak is 8 μ sec. The time from the start to the point where the current has decayed to a certain level is 20 μ sec. The total duration of the pulse is labeled 'Impulse Width'.</p>	
Insulation Resistance	The resistance of gas tube shall be measured each terminal each other terminal. please see above spec	
Capacitance	The capacitance of gas tube shall be measured each terminal to each other terminal. Test frequency :1MHz	



GDT > 3216 series

RELIABILITY INSPECTIONS

Items	Test Condition / Description	Requirement
Cold Resistance	Measurement after -40°C/1000 HRS & normal temperature/2 HRS.	Features are conformed to rated spec.
Heat Resistance	Measurement after 125°C/1000 HRS & normal temperature/2 HRS.	
Humidity Resistance	Measurement after humidity 90~95%(45°C) /1000 HRS & normal temperature/2 HRS.	
Temperature Cycle	10 times repetition of cycle -40°C/30min →normal, temp/2 min →125°C/30min, measurement after normal temp/2 HRS.	
Solder Ability	Apply flux and immerse in molten solder 230±5°C for 3sec up to the point of 1.5mm from body. Check for solder adhesion.	Lead wire is evenly covered by solder.
Solder Heat	Measurement after lead wire is dipped up to the point of 1.5mm from body into 260±5°C solder for 10sec.	Conformed to rated spec.

RECOMMENDED REFLOW PROFILE

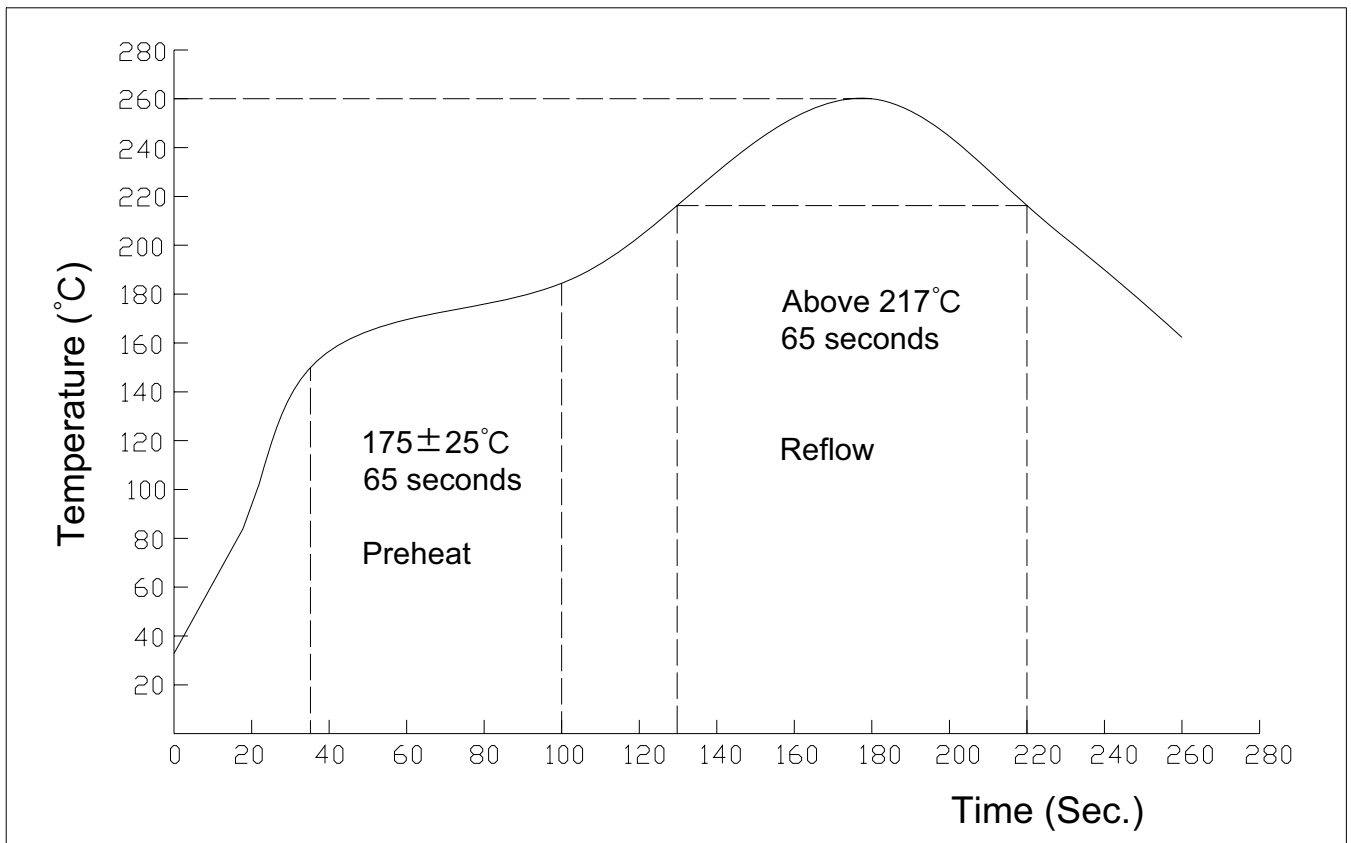



GDT > 3216 series

PACKAGING DIMENSIONS

