

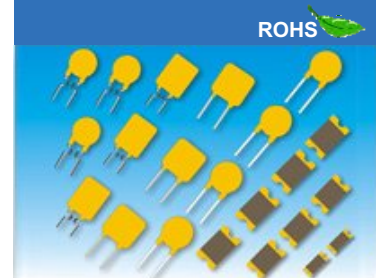

## R-LINE DEVICES – D30 SERIES

### Features

- ◇ Radial leaded devices.
- ◇ Cured, flame retardant epoxy polymer insulating material meets UL94 V-0 requirement.
- ◇ Available in lead-free version.



### Package Dimensions

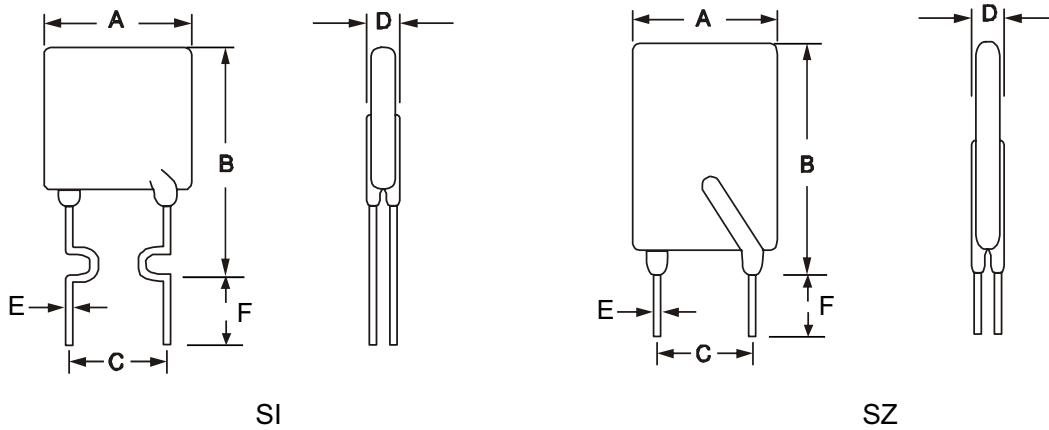

Part Number	A	B	C	D	E	F
	Max.	Max.	±0.6	Max.	Typ.	Min.
D30-090	7.4	14.2	5.1	3.1	0.5	7.6
D30-110	7.4	14.2	5.1	3.1	0.5	7.6
D30-135	9.2	15.8	5.1	3.1	0.5	7.6
D30-160	9.5	16.5	5.1	3.1	0.5	7.6
D30-185	9.8	18.6	5.1	3.1	0.5	7.6
D30-200	15.2	17.2	5.1	3.1	0.5	7.6
D30-250	13.2	20.5	5.1	3.1	0.5	7.6
D30-300	13.2	17.3	5.1	3.1	0.8	7.6
D30-400	14.0	20.1	5.6	3.1	0.8	7.6
D30-500	14.0	20.1	10.5	3.1	0.8	7.6
D30-600	17.5	24.9	10.5	3.1	0.8	7.6
D30-700	17.5	24.9	10.5	3.1	0.8	7.6
D30-800	23.5	29.2	10.5	3.1	0.8	7.6
D30-900	24.3	29.7	10.5	3.1	0.8	7.6



**R-LINE DEVICES – D30 SERIES**

**Electrical Characteristics**

Part Number	$I_H$	$V_{MAX}$	$I_{MAX}$	$R_{MAX}$	$R_{MIN}$	$P_d$ typ.
	(A)	(V)	(A)	( $\Omega$ )	( $\Omega$ )	(W)
D30-090	0.90	30	40	0.220	0.090	0.60
D30-110	1.10	30	40	0.200	0.070	0.70
D30-135	1.35	30	40	0.160	0.055	0.80
D30-160	1.60	30	40	0.140	0.045	0.90
D30-185	1.85	30	40	0.120	0.035	1.00
D30-200	2.00	30	40	0.100	0.040	1.20
D30-250	2.50	30	40	0.080	0.027	1.20
D30-300	3.00	30	40	0.070	0.022	2.00
D30-400	4.00	30	40	0.060	0.010	2.50
D30-500	5.00	30	40	0.050	0.010	3.00
D30-600	6.00	30	40	0.040	0.005	3.50
D30-700	7.00	30	40	0.030	0.005	3.80
D30-800	8.00	30	40	0.025	0.005	4.00
D30-900	9.00	30	40	0.020	0.005	4.20

- $I_H$ =Hold current: maximum current at which the device will not trip at 25°C still air.
- $V_{MAX}$ =Maximum voltage device can withstand without damage at rated current.
- $I_{MAX}$ =Maximum fault current device can withstand without damage at rated voltage.
- $R_{MAX}$ =Maximum device resistance at 25°C prior to tripping.
- $R_{MIN}$ =Minimum device resistance at 25°C prior to tripping.
- $P_{d_{typ}}$ =Typical power dissipation: typical amount of power dissipated by the device when in state air environment.

**Thermal Derating Chart- $I_H$ (A)**

Part Number	Maximum Ambient Operating Temperatures (°C)								
	-20	0	25	30	40	50	60	70	85
D30-090	1.17	1.04	0.90	0.82	0.75	0.69	0.61	0.55	0.47
D30-110	1.43	1.27	1.10	1.00	0.91	0.85	0.75	0.67	0.57
D30-135	1.76	1.55	1.35	1.23	1.12	1.04	0.92	0.82	0.70
D30-160	2.08	1.84	1.60	1.46	1.33	1.23	1.09	0.98	0.83
D30-185	2.41	2.13	1.85	1.68	1.54	1.42	1.26	1.13	0.96
D30-200	2.60	2.30	2.00	1.82	1.66	1.54	1.36	1.22	1.04
D30-250	3.25	2.88	2.50	2.28	2.08	1.93	1.70	1.53	1.30
D30-300	3.90	3.45	3.00	2.73	2.49	2.31	2.04	1.83	1.56
D30-400	5.20	4.60	4.00	3.64	3.32	3.08	2.72	2.44	2.08
D30-500	6.50	5.75	5.00	4.55	4.15	3.85	3.40	3.05	2.60
D30-600	7.80	6.90	6.00	5.46	4.98	4.62	4.08	3.66	3.12
D30-700	9.10	8.05	7.00	6.37	5.81	5.39	4.76	4.27	3.64
D30-800	10.40	9.20	8.00	7.28	6.64	6.16	5.44	4.88	4.16
D30-900	11.70	10.35	9.00	8.19	7.47	6.93	6.12	5.49	4.68



## R-LINE DEVICES – D30 SERIES

### Test Procedures And Requirement

Test	Test Conditions	Accept/Reject Criteria
Resistance	In still air @25°C	$R_{min} \leq R \leq R_{max}$
Time to Trip	Specified current, $V_{max}$ , 25°C	$T \leq \text{max. Time to trip}(T_{tirp})$
Hold Current	30 min, at $I_H$	No trip
Trip Cycle Life	$V_{max}$ , $I_{max}$ , 100 cycles	No arcing or burning
Trip Endurance	$V_{max}$ , 24hours	No arcing or burning

### Average Time Current Curves

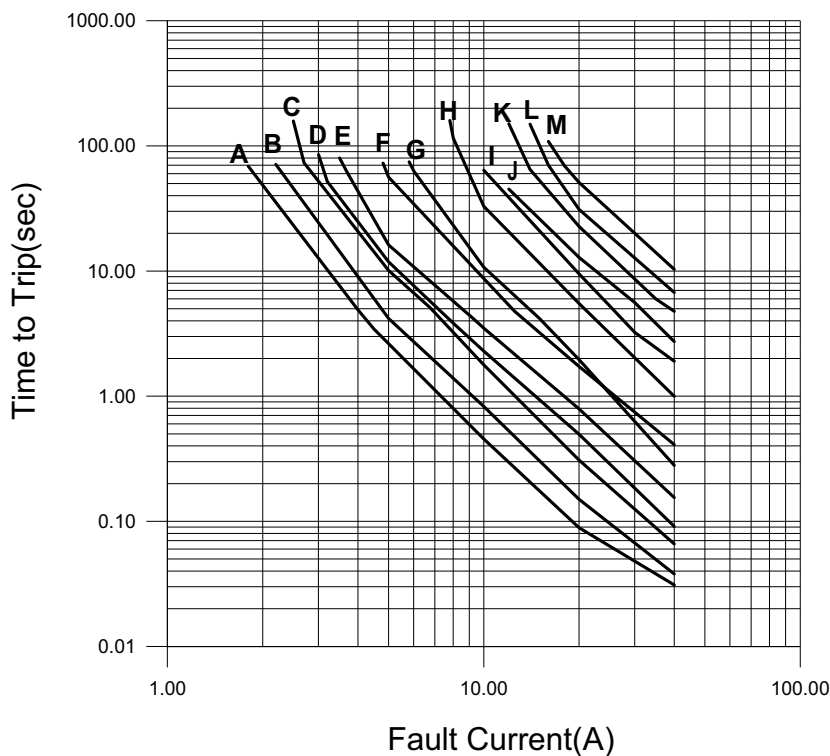

- A = 30-090
- B = 30-110
- C = 30-135
- D = 30-160
- E = 30-185
- F = 30-250
- G = 30-300
- H = 30-400
- I = 30-500
- J = 30-600
- K = 30-700
- L = 30-800
- M = 30-900

### Storage Recommendations

1. Storage Temperature : -10°C ~+40°C
2. Relative Humidity :  $\leq 80\%RH$
3. Keep away from corrosive atmosphere and sunlight.
4. Period of Storage: 1 year.



## R-LINE DEVICES – D30 SERIES

### Wave Soldering Recommendation Parameters

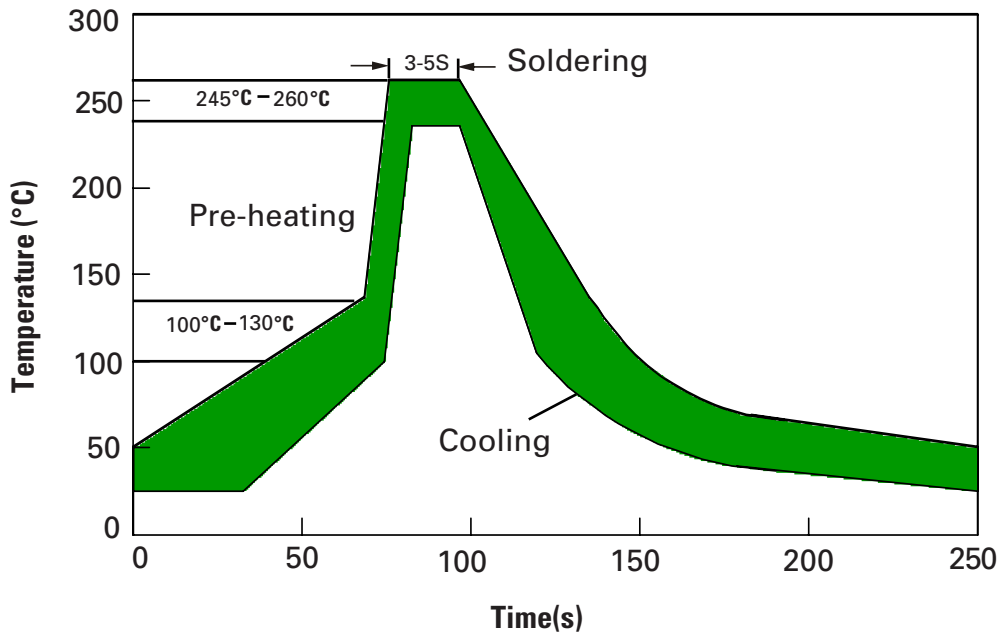

Items	Conditions
Pre-Heating Zone	Refer to the condition recommended by the flux manufacturer. Maximum ramping rate should not exceed 4°C/sec.
Soldering Zone	Maximum solder temperature should not exceed 260°C
Cooling Zone	Forced cooling

### Manual Soldering Recommendation Parameters

Items	Conditions
Soldering condition	The most highest power of the manual soldering electric iron should be 30W or lower than that, soldering temperature should not be higher than 280°C.
Soldering time	The soldering time should be within 3 seconds, or it may lead to the envelope layer cracking, resistance getting bigger.
Soldering position	The soldering position should be controlled distance sea1de feet 4mm above.
Other	The iron soldering head can't touch the body of the product except the lead wire. In the conditions of meeting soldering effect of the product, the soldering lower temperature, nearest distance from the soldering position to chip and less soldering time will make the soldering better.

- Notes: 1. Before using the device must be stored in the original bags, if the storage conditions do not guarantee, the device may not be able to meet the given value.  
 2. The devices can't used for reflow soldering.